

BD35F Direct Current Compressor R134a, 12-24V DC , 10-45V DC Solar & 100-240V AC 50/60Hz

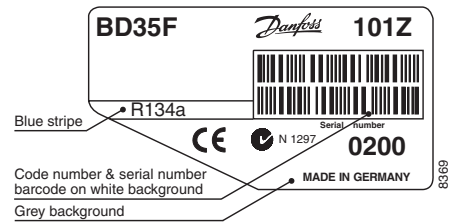

General

Code number (without electronic units)	101Z0200
Electronic unit 12-24V DC - standard	single: 101N0210, 30 pcs: 101N0211
Electronic unit 12-24V DC - with metal shielding	single: 101N0220, 30 pcs: 101N0221
Electronic unit 12-24V DC - with AEO	single: 101N0300, 30 pcs: 101N0301
Electronic unit 10-45V - for solar applications	single: 101N0400, 30 pcs: 101N0401
Electronic unit 12-24V DC & 100-240V AC 50/60Hz	single: 101N0500, 36 pcs: 101N0501
Approved compressor - electronic unit combinations	refer to <i>Technical Info</i> DEHC.EI.100.C
Additional approvals	e4, CE, C-Tick
Compressors on pallet	150



Application

Application	LBP/MBP/HBP
Evaporating temperature °C	-30 to 0 (10)
Voltage range (DC & AC)	12-24V DC & 100-240V AC 50/60Hz 10-45V DC for solar applications
Max. condensing temperature continuous (short) °C	60 (70)
Max. winding temperature continuous (short) °C	125 (135)

Cooling requirements

Application	LBP	MBP	HBP
32°C	S	S	S
38°C	S	S	S
43°C	S	S	S

Remarks on application: Fan cooling F₁ depending on application and speed.

Motor

Motor type	Variable speed
Resistance, all 3 windings (25°C) Ω	2.2

Design

Displacement cm ³	2.00
Oil quantity (type) cm ³	150 (polyolester)
Maximum refrigerant charge g	300
Free gas volume in compressor cm ³	870
Weight - Compressor/Electronic unit kg	4.3/0.25

Dimensions

Height mm	A	137
	B	135
	B1	128
	B2	73
Suction connector location/I.D. mm angle	C	6.2 41.5°
Process connector location/I.D. mm angle	D	6.2 45°
Discharge connector location/I.D. mm angle	E	5.0 21°
Connector tolerance I.D. mm		±0.09, on 5.0 +0.12/+0.20

Standard battery protection settings (no connection C - P)

12V cut-out [V]	12V cut-in [V]	24V cut-out [V]	24V cut-in [V]
10.4	11.7	22.8	24.2

Optional battery protections settings (not possible with electronic unit 101N0400)

Resistor (R2) [kΩ]	12V cut-out [V]	12V cut-in [V]	12V max. Voltage [V]	24V cut-out [V]	24V cut-in [V]	24V max. Voltage [V]
0	9.6	10.9	17.0	21.3	22.7	31.5
1.6	9.7	11.0	17.0	21.5	22.9	31.5
2.4	9.9	11.1	17.0	21.8	23.2	31.5
3.6	10.0	11.3	17.0	22.0	23.4	31.5
4.7	10.1	11.4	17.0	22.3	23.7	31.5
6.2	10.2	11.5	17.0	22.5	23.9	31.5
8.2	10.4	11.7	17.0	22.8	24.2	31.5
11	10.5	11.8	17.0	23.0	24.5	31.5
14	10.6	11.9	17.0	23.3	24.7	31.5
18	10.8	12.0	17.0	23.6	25.0	31.5
24	10.9	12.2	17.0	23.8	25.2	31.5
33	11.0	12.3	17.0	24.1	25.5	31.5
47	11.1	12.4	17.0	24.3	25.7	31.5
82	11.3	12.5	17.0	24.6	26.0	31.5
220	9.6	10.9				31.5

- S = Static cooling normally sufficient
- O = Oil cooling
- F₁ = Fan cooling 1.5 m/s
(compressor compartment temperature equal to ambient temperature)
- F₂ = Fan cooling 3.0 m/s necessary
- SG = Suction gas cooling normally sufficient
- = not applicable in this area

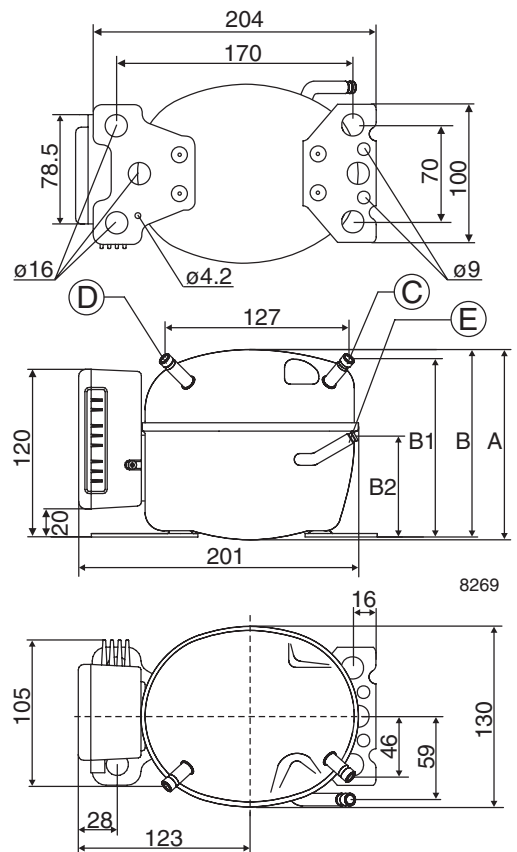

Capacity (EN 12900 Household/CECOMAF)												12V DC static cooling		watt	
rpm \ °C	-30	-25	-23.3	-20	-15	-10	-5	0	5	7.2	10	15			
2,000	15.8	23.9	26.9	33.1	43.8	56.6	71.7	89.9	111	122	136				
2,500	20.2	29.9	33.5	41.2	54.6	70.7	89.7	112	139	152					
3,000	22.5	32.4	36.5	45.4	61.8	81.7	105	133							
3,500	26.2	35.9	40.4	50.5	69.8	93.6	122								

Capacity (ASHRAE LBP)												12V DC static cooling		watt	
rpm \ °C	-30	-25	-23.3	-20	-15	-10	-5	0	5	7.2	10	15			
2,000	19.5	29.4	33.1	40.7	54.0	69.8	88.6	111	137	151	169				
2,500	24.9	36.8	41.3	50.7	67.3	87.1	111	139	172	189					
3,000	27.7	39.9	44.9	55.9	76.1	101	130	164							
3,500	32.2	44.2	49.7	62.2	86.0	115	150								

Power consumption												12V DC static cooling		watt	
rpm \ °C	-30	-25	-23.3	-20	-15	-10	-5	0	5	7.2	10	15			
2,000	17.6	23.4	25.3	28.7	33.6	38.3	43.0	48.0	53.4	56.0	59.5				
2,500	23.3	30.9	33.3	37.8	44.1	50.2	56.2	62.3	68.7	71.7					
3,000	29.9	36.0	38.3	43.0	50.7	58.7	66.8	74.8							
3,500	36.0	42.8	45.4	50.8	59.5	68.9	78.5								

Current consumption (for 24V applications the following must be halved)												12V DC static cooling		A	
rpm \ °C	-30	-25	-23.3	-20	-15	-10	-5	0	5	7.2	10	15			
2,000	1.5	2.0	2.1	2.4	2.8	3.2	3.6	4.0	4.5	4.67	5.0				
2,500	1.9	2.6	2.8	3.2	3.7	4.2	4.7	5.2	5.8	5.98					
3,000	2.5	3.0	3.2	3.6	4.2	4.9	5.6	6.2							
3,500	3.0	3.6	3.8	4.3	5.0	5.7	6.5								

COP (EN 12900 Household/CECOMAF)												12V DC static cooling		W/W	
rpm \ °C	-30	-25	-23.3	-20	-15	-10	-5	0	5	7.2	10	15			
2,000	0.90	1.02	1.06	1.15	1.31	1.48	1.67	1.87	2.08	2.17	2.29				
2,500	0.87	0.97	1.01	1.09	1.24	1.41	1.60	1.80	2.02	2.12					
3,000	0.75	0.90	0.95	1.06	1.22	1.39	1.58	1.78							
3,500	0.73	0.84	0.89	1.00	1.17	1.36	1.55								

COP (ASHRAE LBP)												12V DC static cooling		W/W	
rpm \ °C	-30	-25	-23.3	-20	-15	-10	-5	0	5	7.2	10	15			
2,000	1.10	1.25	1.31	1.42	1.61	1.82	2.06	2.31	2.57	2.70	2.84				
2,500	1.07	1.19	1.24	1.34	1.53	1.74	1.97	2.23	2.50	2.63					
3,000	0.93	1.11	1.17	1.30	1.50	1.72	1.95	2.20							
3,500	0.89	1.03	1.09	1.23	1.44	1.68	1.91								

Operational errors shown by LED (optional)

Number of flashes	Error type
5	Thermal cut-out of electronic unit (If the refrigeration system has been too heavily loaded, or if the ambient temperature is high, the electronic unit will run too hot).
4	Minimum motor speed error (If the refrigeration system is too heavily loaded, the motor cannot maintain minimum speed at approximately 1,850 rpm).
3	Motor start error (The rotor is blocked or the differential pressure in the refrigeration system is too high (>5 bar)).
2	Fan over-current cut-out (The fan loads the electronic unit with more than 1A _{peak}).
1	Battery protection cut-out (The voltage is outside the cut-out setting).

Wire Dimensions DC

Cross section	Size AWG	Max. length* 12V operation		Max. length* 24V operation	
		[m]	[ft.]	[m]	[ft.]
2.5	12	2.5	8	5	16
4	12	4	13	8	26
6	10	6	20	12	39
10	8	10	33	20	66

*Length between battery and an electronic unit

Wire dimensions AC

Cross section min. 0.75 mm² or AWG 18

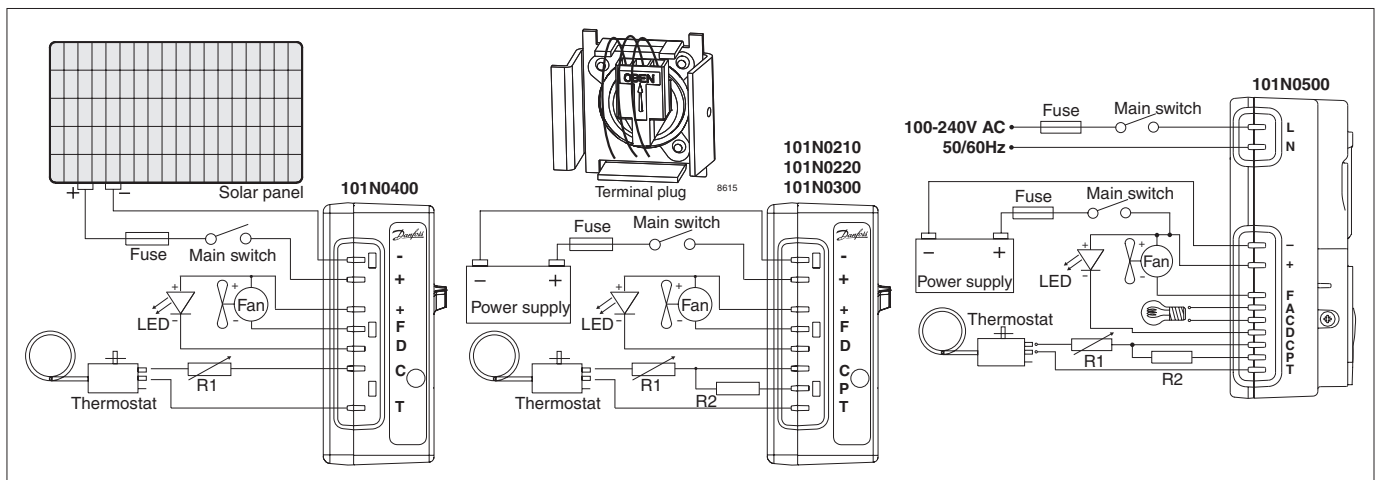

Compressor speed

Electronit unit Code number	Resistor (R1) [Ω]	Motor speed [rpm]	Control circuit current [mA]
101N0210 101N0220 101N0500	0	2,000	5
	277	2,500	4
	692	3,000	3
	1523	3,500	2
101N0300 101N0400 with AEO	0	AEO	6
	173	2,000	5
	450	2,500	4
	865	3,000	3
	1696	3,500	2

Test conditions

	EN 12900/CECOMAF	ASHRAE
Condensing temperature	55°C	54.4°C
Ambient temperature	32°C	32°C
Suction gas temperature	32°C	32°C
Liquid temperature	no subcooling	32°C

Accessories for

	BD35F	Code number
Bolt joint for one compressor	Ø: 16 mm	118-1917
Bolt joint in quantities	Ø: 16 mm	118-1918
Snap-on in quantities	Ø: 16 mm	118-1919
Remote kit (without cable)		105N9210
AC line cord (UL approved/VDE approved)		105N9520/30
DC usage: Std. automobile fuse 12V: 15A / 24V: 7.5A Main switch: rated to min. 20A		Not deliverable from Danfoss
AC usage: Fuse 100-240V: 4A / Main switch: min. 6A		

In AEO (Adaptive Energy Optimizing) speed mode the BD compressor will always adapt its speed to the actual cooling demand.

Danfoss can accept no responsibility for possible errors in catalogues, brochures and other printed material. Danfoss reserves the right to alter its products without notice. This also applies to products already on order provided that such alterations can be made without consequential changes being necessary in specifications already agreed. All trademarks in this material are property of the respective companies. Danfoss and the Danfoss logotype are trademarks of Danfoss A/S. All rights reserved.