

Manual

Controller for temperature control
- EKC 201 and EKC 301



ADAP-KOOL®
Refrigeration control system

Introduction

Application

The controller is a simple thermostat regulator in which some refrigeration-technical functions have been integrated so that it can replace a link-up of a group of thermostats and timers. The controller has been specially designed for refrigeration applications, but may of course also be used for other forms of regulation where this is expedient.

The controller comes in several versions with a growing number of functions - from the simple one with just one relay to more advanced versions with three relays. All versions are furthermore available with an alarm function. The number of relays will then be increased by one.

The relays are used for controlling:

- compressor
- fan
- defrost
- alarm

One of the connections to the controller is a digital input. This input will register the position of a connected switch and depending on the functions you want to use, it will work, as follows:

- activate a door alarm if the door remains open for longer than allowed
- start a defrost
- or transmit the signal to the data communication

Advantages

- One electronic controller is able to replace several traditional controllers and defrost clocks
- Can be supplied for panel as well as DIN-rail mounting
- Temperatures, times, operating conditions, parameter codes and alarm and fault codes can be read from the display
- Three LEDs indicate the actual condition of the system:
 - refrigeration
 - defrost
 - fan running
- Easy to re-establish factory setting
- In the event of error function, the actual parameter code can be displayed
- All alarms are indicated by the three LEDs flashing at once
- Easy to install data communication at a later date

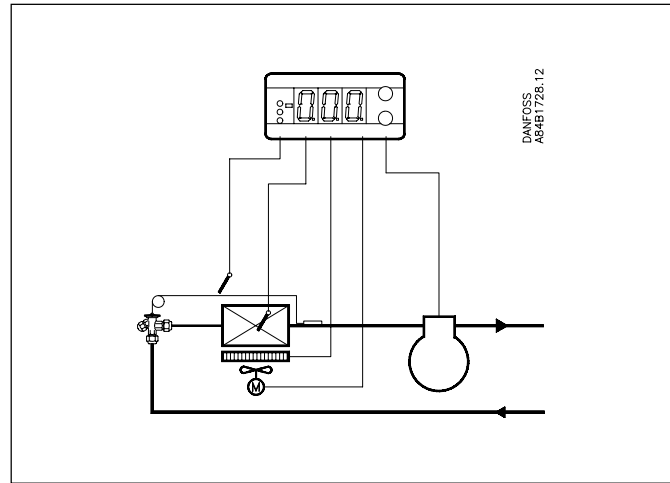

Accessories

The controller can be extended by one insertion module if the application warrants it.

The controller comes prepared with plug and terminals, so all you have to do is to push the module into place.

If you want to change the periodical defrost, so that it can be performed at specific times of the day, a clock module may be fitted.

Up to six defrost cycles per day can now be set. The module is provided with battery backup. (Type = EKA 172)

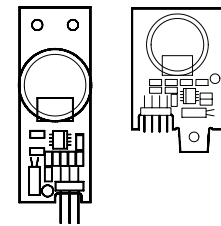

For EKC 201

For EKC 301

If it is required that operation is to take place from a PC, a data communication module must be placed in the controller.

Two types of insertion modules for data communication can be had - they are LON modules with FFT10 interface or RS485 interface.

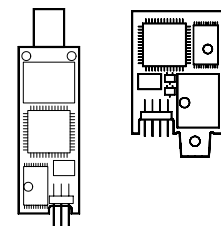

For EKC 201

For EKC 301

Controller application overview

Function	Application no.			
	1	2	3	4
Room temperature control by pump down or compressor start/stop				
Natural defrost				
Temperature controlled defrost with electricity or hot gas				
Time-controlled defrost with electricity or hot gas				
Fan motor control				

Example: Controller for application number 3 satisfies requirement for

- room temperature control (thermostat) by pump down or compressor start/stop.
- time controlled defrost using hot gas or electricity
- fan motor control

<p>Application no. 1</p> <p>DANFOSS AA4B1736.12</p>			<p>DANFOSS AA4B1737.14</p>					
<p>Room temperature control by pump down. Natural defrost on pump down.</p>			<p>Room temperature control by compressor start/stop. Natural defrost on compressor stop.</p>					
<p>Application no. 2</p> <p>DANFOSS AA4B1734.14</p>			<p>DANFOSS AA4B1733.11</p>			<p>DANFOSS AA4B1736.12</p>		
<p>Room temperature control by pump down. Temperature-controlled electric defrost.</p>			<p>Room temperature control by pump down. Temperature-controlled hot gas defrost.</p>			<p>Room temperature control by compressor start/stop. Temperature-controlled electric defrost.</p>		
<p>Application no. 3</p> <p>DANFOSS AA4B1730.11</p>			<p>DANFOSS AA4B1729.12</p>			<p>DANFOSS AA4B1733.12</p>		
<p>Room temperature control by pump down. Time-controlled electric defrost.</p>			<p>Room temperature control by pump down. Time-controlled hot gas defrost.</p>			<p>Room temperature control by compressor start/stop. Time-controlled electric defrost.</p>		
<p>Application no. 4</p> <p>DANFOSS AA4B1736.12</p>			<p>DANFOSS AA4B1726.13</p>			<p>DANFOSS AA4B1726.12</p>		
<p>Room temperature control by pump down. Temperature-controlled electric defrost.</p>			<p>Room temperature control by pump down. Temperature-controlled hot gas defrost.</p>			<p>Room temperature control by compressor start/stop. Temperature-controlled electric defrost.</p>		

Survey of functions

Functions	Parameter	Operation via data communication
Thermostat function		Thermostat
Reference Thermostat regulates on the basis of the set value. A change of the set value can be limited/lock with the setting of r02 and r03.	-	Temp. setpoint
Differential When the temperature is higher than the reference value + the set differential, the compressor relay will be cut in. It will cut out again when the temperature drops to the set reference value. <div style="text-align: center;"> </div>	r01	Differential
Reference limitation The controller's setting range for the reference may be narrowed down, so that much too high or much too low values are not set accidentally - with resulting damages. With these settings it will only be possible to set the reference between the two values.		
To avoid a too high setting of the reference, the max. allowable reference value must be lowered.	r02	Max lim. temp SP
To avoid a too low setting of the reference, the min. allowable reference value must be increased.	r03	Min lim. temp SP
Correction of temperature display If the temperatures at the room sensor and at the controller are not identical, an offset adjustment of the registered temperature may be made. This function is used when too long sensor cables have to be corrected.	r04	Temp calibration
Temperature unit Set here if the controller is to show temperature values in °C or in °F.	r05	Temp. unit °C=0 (Only °C on AKM, whatever the setting)
Alarm settings		Alarm Settings
The controller can give alarm in various situations. When there is an alarm, all the LED's at the front of the controller flash. If the controller is provided with an alarm relay, it will also be activated.		
Upper deviation Here you set when the alarm at high temperature is to become activated. The value is set in K. The alarm will start if the temperature exceeds the set "reference" + "differential" + "upper deviation".	A01	Upper deviation
Lower deviation Here you set when the alarm at low temperature is to become activated. The value is set in K. The alarm will start if the temperature goes below the set "reference" minus the "lower deviation".	A02	Lower deviation
Temperature alarm delay If one of the two limit values is exceeded, a timer function will start. The alarm will only become visible, when a set time delay has been passed. The time delay is set in minutes.	A03	Temp alarm delay
Door alarm time delay If the digital input is used for a door monitoring function (see definition in section "Miscellaneous") an alarm will only come after a given period with the door open. The time delay is set in minutes.	A04	Door alarm delay
		Reset alarm The function resets all alarms when set in pos. ON.
		Alarm stat/relay Here you can read the alarm status. If the controller is provided with alarm relay, you can force-control the relay in the "Manual control" mode.

Compressor function		Compressor
The compressor relay works in conjunction with the thermostat. When the thermostat calls for refrigeration, the compressor relay will be cut in.		
Running time To prevent repeated stop-and-go operation, values can be set for how long the compressor is to run once it has been started. And for how long it must at least be stopped.		
Min. ON-time (in min.)	c01	Min. ON-time
Min. OFF-time (in min.)	c02	Min. OFF-time
Safety function in connection with sensor errors If the room sensor becomes defective (is shortcircuited or cut out), the controller will start a regulating frequency of the compressor at the same time as an alarm is sounded for the sensor error. If the controller has been operating for so long that the compressor relay has been cut out 72 times, the controller will remember the various ON/OFF-times of the compressor relay. Regulation will then continue with the well-known average ON/OFF period. Conversely, if the controller has not accomplished the 72 periods, the regulation will use a timeperiod of 20 minutes. During these 20 minutes the compressor will be started and stopped with this percentage setting. A setting of, say, 40% will cut out the relay for 8 out of the 20 minutes.	c03	Cutin frequency
Compressor stop at open door If a digital input is used for a door monitoring function (see definition in section "Miscellaneous"), the compressor may be stopped when the door is opened. With the setting YES (ON) the compressor will be stopped.	c04	Cmp out door opn
		Compressor relay Here you can read the relay status, or you can force-control the output. In "Manual Control" mode.
Defrost		Defrost
The controller contains a timer function, so that the defrost can start periodically, e.g. every eight hours. If defrost is performed at certain times of the day, the setting must be made, so that it fits into this sequence; but the controller could also be provided with a module containing a real-time clock. If this clock is mounted, defrost can be started at fixed times of the day. In controllers with a defrost relay you can set whether the defrost is to be made with electricity or hotgas. The actual defrost can be stopped based on time, or a temperature sensor may be placed on the evaporator, so that defrost can be stopped at a temperature value.		
Defrost method Here you set whether defrost is to be accomplished with electricity or hotgas. During defrost the defrost relay will be cut in. The setting will have an influence on the compressor relay's function during defrost. When ELECTRICITY is used, the compressor relay will not be activated, but when GAS is used, the relay will be cut in.	d01	Def. method EL=0
Defrost stop temperature When a defrost sensor is mounted on the evaporator, defrost can be stopped at a given temperature. The temperature value is set. If a defrost sensor has not been mounted, defrost will be stopped on time basis. See later.	d02	Def. stop temp
Interval between defrost starts There are two ways of setting the interval. Either you put the function in pos. OFF or you set an interval. Set it in pos OFF if you start the defrost by means of input DI or if you mount a real-time Module in the controller. Interval: Here you simply set how often defrost is to be started.	d03	Defrost interval
Max. defrost duration If you have chosen to stop defrost on the basis of temperature, this setting will be a safety period where defrost will be stopped, if a stop based on temperature has not already taken place. If you have chosen stop based on time, this setting will be the defrost time.	d04	Max defrost time

<p>Time staggering for defrost cutins during start-up The function is only relevant if you have several refrigeration appliances or groups where you want the defrost to be staggered. The function is furthermore only relevant if you have chosen defrost with interval start (d03). The function delays the defrost with the set number of minutes, but only for the very first defrost after energy has been supplied to the controller.</p>	d05	Time staggering
<p>Drip-off time Here you set the time that is to elapse from a defrost and until the compressor is to start again. (The time when water drips off the evaporator).</p>	d06	Drip-off time
<p>Delay of fan start after defrost Here you set the time that is to elapse from compressor start after a defrost and until the fan may start again. (The time when water is “tied” to the evaporator).</p>	d07	Fan start delay
<p>Fan start temperature The fan may also be started a little earlier than mentioned under “Delay of fan start after defrost”, if the defrost sensor registers an allowable value. Here you can set the value at which the fan may start.</p>	d08	Fan start temp.
<p>Fan cut in during defrost Here you can set whether fan is to operate during defrost.</p>	d09	Fan during def.
<p>Defrost sensor Here you can set whether a defrost sensor has been mounted.</p>	d10	Defrost sensor
<p>Delay of temperature alarm after defrost During and immediately after a defrost the temperature is “too high”. The “high temperature alarm” can be suppressed just after a defrost. Here you set for how long the alarm is to be suppressed.</p>	d11	Def. alarm delay
<p>Delay of display after defrost stop During and immediately after a defrost the temperature is “too high”. The display of this “too high temperature” is cancelled during the defrost and can furthermore be suppressed right after a defrost. Here you set for how long the exact measuring is to be suppressed. During and immediately after a defrost the display will show the temperature measured just before defrost was started.</p>	d12	Delay display
<p>Defrost at power-up Here you can set whether the controller is to start with a defrost, if the power has been cut.</p>	d13	Def. at power up
		Defrost start Here you can start a manual defrost
		Def. stat/relay Here you can read the defrost relay status or you can force-control the relay in “Manual control” mode.
If you want to see the temperature at the defrost sensor, push the controller’s lower button.		Defrost temp. The temperature at the defrost sensor is shown here.
Fan function		Fan
In addition to the fan functions concerning defrost the fans may also be stopped as a function of the compressor operation and a possible door function.		
<p>Fan stopped at cut-out compressor Here you can select whether the fan is to be stopped when the compressor is cut out</p>	F01	Fan stp comp out
<p>Delay of fan stop when compressor is cut out If you have chosen to stop the fan when the compressor is cut out, you can delay the fan stop when the compressor has stopped. Here you can set the time delay.</p>	F02	Fan del comp out
<p>Fan stop at open door If you have selected the DI-input for monitoring a door switch, you may also stop the fan when the door is registered open. Select yes or no for the function.</p>	F03	Fan out door opn
		Fan relay Here you can read the fan relay status, or force-control the relay in “Manual control” mode.

Miscellaneous		Miscellaneous
Delay of output signals at start-up During start-up or after a power failure the controller's functions can be delayed, so that any overloading of the electric network can be avoided. Here you can set the time delay.	o01	Delay of output
Digital input signal The controller has a digital input DI which can be used for one of the following functions: 1) Door alarm. A door switch is connected and the controller will register when the DI input is open. The controller will now allow the functions "door alarm", "compressor stop at open door" and "fan stop at open door". When the time for door alarm (A04) expires, a failsafe function will enter into force (compressor and fan will be started). 2) Defrost. A switch function with spring return is connected. The controller will register when the DI input is cut in.. It will then start a defrost cycle. If the signal is received by several controllers, it is important that ALL connections are mounted identically (DI to DI and GND to GND). It is also a must that each controller receives power from its own, separate power supply unit. 3) Data communication. If a module with data communication is mounted, the controller can send the status of the switch function to the data communication network. 4) Main switch. Start / stop control. 0) The setting is set at 0 when the DI input is not used.	o02	Di input control
Access code If the settings in the controller are to be protected by an access code, you can set a numerical value between 1 and 100. If not, you may cancel the function by means of setting OFF.	o05	
Sensor type Normally a PT 1000 sensor with great signal accuracy is used. But you may also use a PTC sensor (R25=1000) in special situations. When a PT 1000 sensor is used, the temperature will be shown with one decimal (0.1). If a PTC sensor is used, the temperature will be shown in whole figures (1).	o06	Sensor type Pt=0
Factory setting If you need to reset the controller and reinstate the factory-set values, do the following: Remove the power supply - keep both buttons down at the same time as you reconnect the power supply.		Reset to factory If you put this setting in pos. ON, you reinstate the factory-set values
		Dig. input state Here you can read the status of the digital input
Address		
If the controller is hooked up to a network with data communication it needs an address, and the master gateway on the data communication network must then know this address. These settings can only be made when a data communication module has been mounted in the controller and the installation of the data communication cable has been concluded. This installation is mentioned in a separate document, "RC.8A.C".		After installation of a data communication module the controller is operated on an equal footing with the other controllers in the ADAP-KOOL® refrigeration controls
The address is set between 1 and 60	o03	
The address is transmitted to the gateway when the menu is put in pos. ON.	o04	
Real-time clock		
The controller can accommodate one insertion module which may either be a data communication module or a real-time clock. When a data communication module is mounted, the controller may be fitted with a Danfoss gateway type AKA 243. The operation of the controller can now be carried out via the data communication. Cf. separate literature.		
Real-time clock With this module you can set up to six individual times for defrost starts per 24 hours.	t01 t06	
Hour setting	t07	
Minute setting	t08	

Trouble-shooting		Alarms
<p>When there are faults and defects the LED's at the front will flash, and if it is a model with an alarm relay, the relay will become activated. If you push the top button in this situation, you will be able to see the alarm message in the display. There are two kinds of error reports - either an alarm occurring during the daily operation, or a defect in the installation. Here is a list of the messages that can appear:</p>		
High-temperature alarm	A1	High temp. alarm
Low-temperature alarm	A2	Low temp. alarm
Door alarm	A4	Door alarm
(A-alarms will only become visible when the set time delay has expired. E-alarms will however be visible as soon as the defect occurs).		
Faults in the controller	E1	Fault in EKC
Cut-out room sensor	E2	Air sensor o.c.
Shortcircuited room sensor	E3	Air sensor s.c.
Cut-out defrost sensor	E4	Def. sensor o.c.
Shortcircuited defrost sensor	E5	Def. sensor s.c.
Alarm destinations		
		The importance of the individual alarms can be defined by means of a setting (0, 1, 2 or 3). Cf. the AKM literature
Operating status		
<p>The controller will experience some control situations where it is simply waiting for the next stage of the regulation. To make these "why is nothing going on" situations visible, check the operating status in the display. Push the uppermost button (1s) briefly. If there is a status code it will be shown in the display. They mean the following:</p>		(Measurement)
S2: When the compressor is operating, it must run for at least x minutes.		EKC state: 0 = regulation 2
S3: When the compressor is stopped, it must remain stopped for at least x minutes.		3
S4: The evaporator is dripping off and waiting for the time to expire.		4
General		
Air temperature (measurement)		Air temperature
Manual operation; 0 = normal, 1 = service (relays can be force-controlled).		Manual control

Data

Supply voltage	Panel version	12 V a.c./d.c. +15/-15% 230 V +10/-15%, 50/60 Hz (certain versions)
	DIN version	230 V +10/-15%, 50/60 Hz
Power consumption	Panel version	2.5 VA
	DIN version	5.0 VA
Transformer	12 V controllers must be connected to separate transformer of min. 3 VA	
Sensors	Pt 1000 ohm or PTC ($R_{25} = 1000 \text{ ohm}$)	
Controller sensor system	Measuring range	-60 to +50°C
	Accuracy	±0,5°C for sensor temperature -35 to +25°C; ±0.1°C for sensor temperature -60 to -35°C +25 to +50°C
Display	LED, three digits (0.1% read-off accuracy in measuring range)	
External alarm contact	Standard SPST contact (door alarm)	
Electrical connection cable	Panel version	max. 1.5 mm ² multi-core cable
	DIN version	max. 2.5 mm ² multi-core cable
Relays	Controller relay	SPST NO, $I_{max} = 6 \text{ A ohmic} / 3 \text{ A AC } 15^{\circ} \text{ inductive}$
	Defrost relay	SPST NO, $I_{max} = 6 \text{ A ohmic} / 3 \text{ A AC } 15^{\circ} \text{ inductive}$
	Fan motor relay	SPST NO, $I_{max} = 6 \text{ A ohmic} / 3 \text{ A AC } 15^{\circ} \text{ inductive}$
	Alarm relay	SPST NC, $I_{max} = 4 \text{ A ohmic} / 1 \text{ A AC } 15^{\circ} \text{ inductive}$ $I_{min} = 1 \text{ mA on } 100 \text{ mV}^{**}$
Ambient temperature	Operation	0 to +55°C
	Transport	-40 to +70°C
Enclosure	Panel version	IP 54
	DIN version	IP 20
Approvals	EU low-voltage directive and EMC stipulations on CE marking are complied with. LVD-tested to EN 60730-1 and EN 60730-2-9 EMC-tested to EN 50081-1 and EN 50082-1	

* AC 15 load to EN 60947-5-1

** Gold plating ensures make function with small contact loads

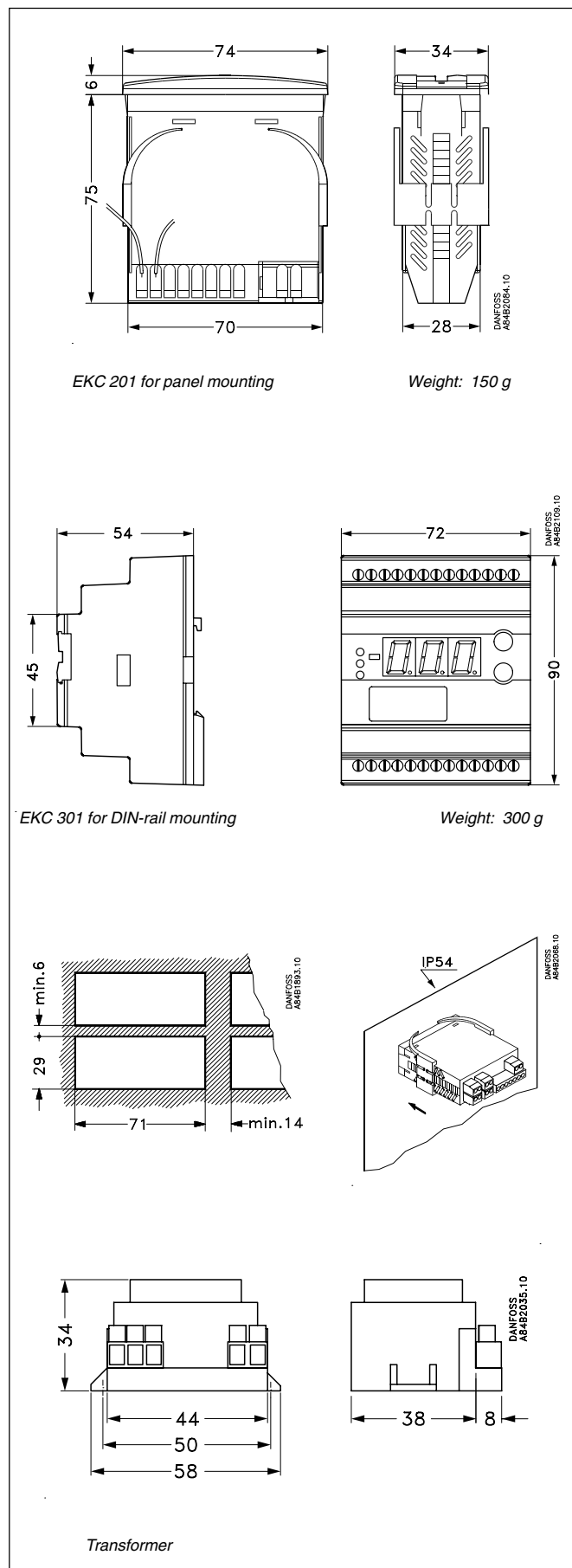

Electrical connection

Application 1
without alarm relay

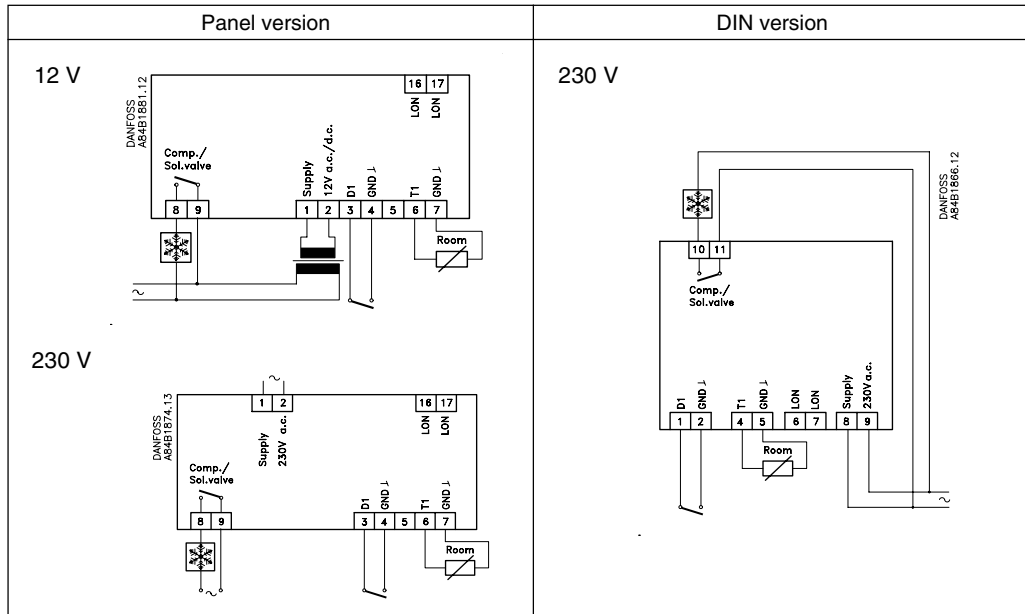

Application 2
without alarm relay

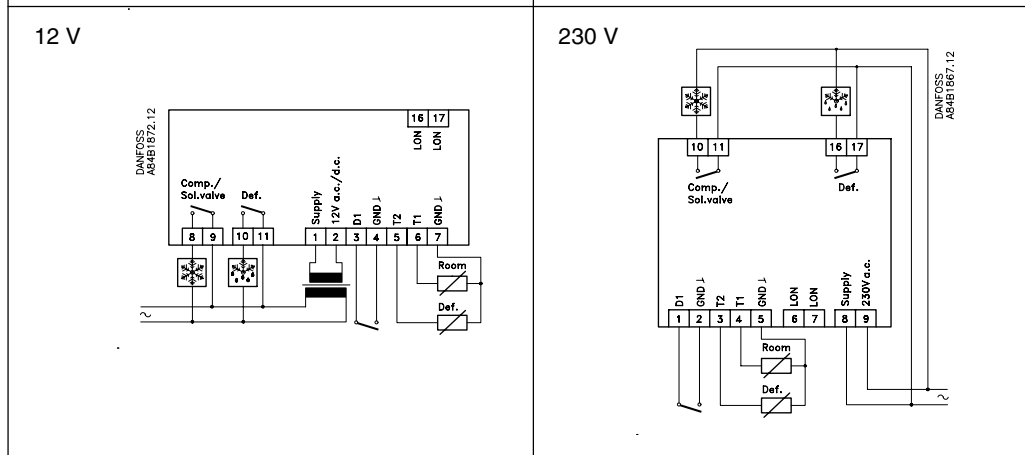

Application 3 and 4
without alarm relay

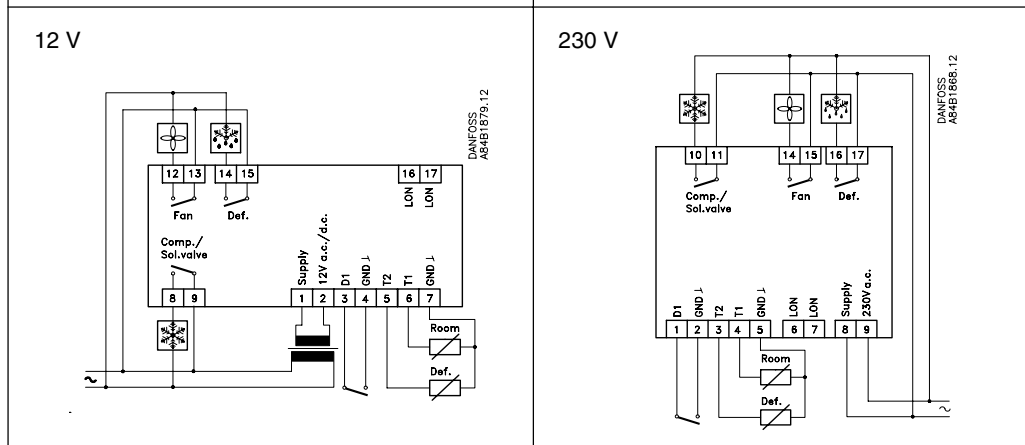

Application 1
with alarm relay

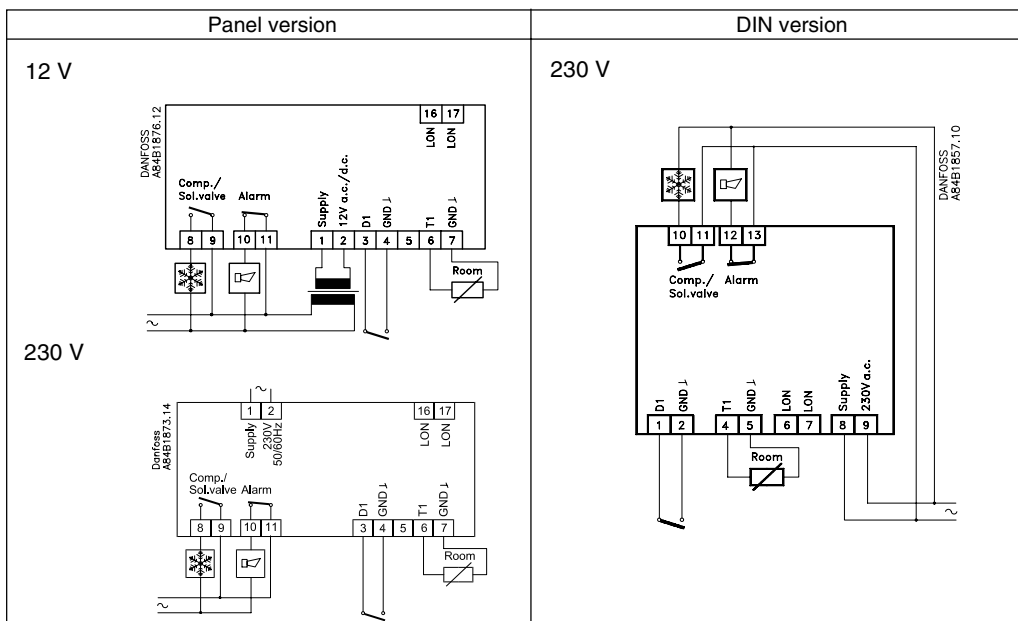

Application 2
with alarm relay

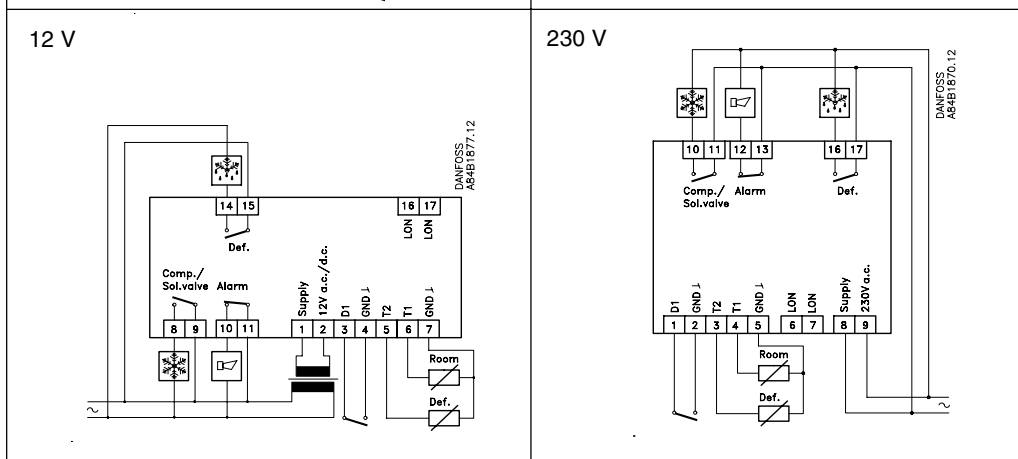

Application 3 and 4
with alarm relay

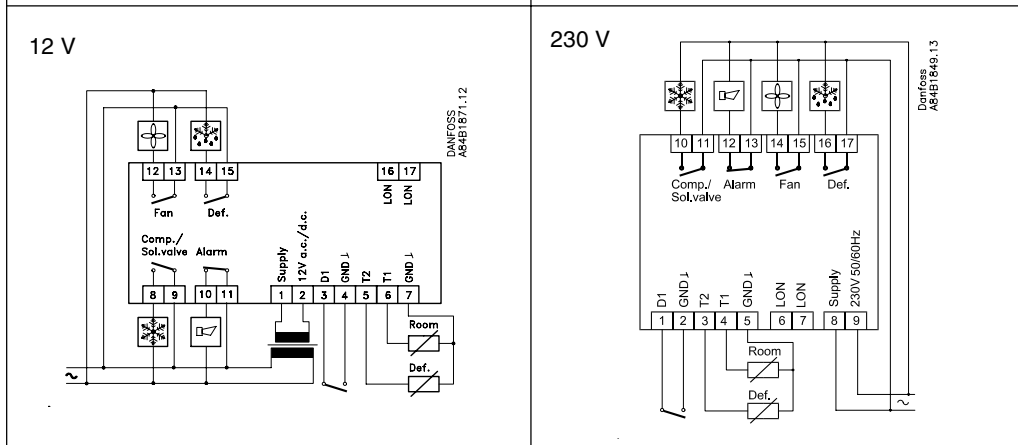

60 Hz:

If the net frequency is 60 Hz there will be the following limitations:

EKC 201, 12 V: - Cable length between transformer and EKC must be max. 1 m.
 - Nothing but the EKC must be connected to the transformer's secondary side
 - Cable length between sensors and EKC must be max. 100 m

EKC 301: - Cable length between sensors and EKC must be max. 100 m

Operation

Display

The values are displayed with three digits and by means of a setting you can decide whether they are to be shown in °C or °F.

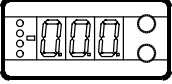

Light-emitting diodes on the front plate

There are up to three LED's on the front plate. They signify the following:

- refrigeration
- defrost
- fan operating

Buttons

If you want to change a setting, the two buttons will give you a higher or lower value depending on which button you push. But before you can change the value, you require access to the menu.

You obtain it by pushing the top button for a couple of seconds -you will then enter into the row of parameter codes. Find the parameter code you want to change and then push the two buttons simultaneously.

When you have changed the value, save the new value by pushing the two buttons simultaneously once more.

Briefly:

- gives access to the menu
- gives access to changing of values
- saves a change

Temperature setting

If it is the temperature setting you want to change, do not enter into the menu. Just push the two buttons simultaneously, and you will be able to change the temperature reference when the display responds by flashing.

Forced control

In addition to the normal operation of the controller you can carry out a number of forced control functions which you start in the following manner:

- Cut-out of alarm relay / see alarm code
 - Push the upper button
- Reading of defrost sensor's temperature
 - Push the lower button
- Manual start or stop of a defrost
 - Push the lower button for four seconds

What to do	Initial controller setup	Operating the two pushbuttons What the controller does automatically	Resulting controller setup
Read or change room temp. setting	Normal operation Room temp. 1		Normal operation Room temp. 2
Read or change parameter codes and settings	Normal operation (or alarm) Unknown codes and settings		Normal operation (or alarm) Known codes and settings
Re-establish all factory settings	Unknown settings		All parameter settings = factory settings
Read defrost sensor temp.	Normal operation or alarm		Normal operation
Manually start of a defrost operation	Normal operation		Normal operation
Manually stop of a defrost operation	Defrost operation		Normal operation
Reset alarm relay	Alarm relay activated		Alarm relay not activated
Read codes cause of alarm mode	Alarm relay not activated		Alarm

Examples of operations

See the temperatur at the other controls sensor

1. Push the two buttons simultaneously

See the temperatur at the defrost sensor

1. Push the lower button

Set of a menu

1. Push the upper button until a parameter is shown
2. Push one of the buttons and find the parameter you want to change
3. Push both buttons simultaneously until the parameter value is shown
4. Push one of the buttons and select the new value
5. Push both buttons again to conclude the setting

Menu survey

Setting and read-off parameters	Parameter codes	Controller application no.				Min. value	Max. value	Factory setting ⁵⁾	Actual setting
		1	2	3	4				
Normal operation									
Temperature controller, Temperature						-60°C	50°C	3°C	
Thermostat									
Differential ¹⁾	r01					0.1 K	20 K	2 K	
Max. limitation of set temperature	r02					-59°C	50°C	50°C	
Min. limitation of set temperature	r03					-60°C	49°C	-60°C	
Adjustment of temperature indication	r04					-20 K	20 K	0.0 K	
Temperature unit (°C/°F)	r05							°C	
Alarm									
Upper deviation (above temp. setting + differential ²⁾)	A01					0 K	50 K	10 K	
Lower deviation (below temp. setting ²⁾)	A02					-50 K	0 K	-10 K	
Temperature alarm delay	A03					0 min	90 min	30 min	
Door alarm delay	A04					0 min	90 min	60 min	
Compressor									
Min. ON-time	c01					0 min	15 min	0 min	
Min. OFF-time	c02					0 min	15 min	0 min	
Cut-in frequency on sensor fault ³⁾	c03					0 %	100 %	0 %	
Compressor stop at open door (yes/no)	c04							no	
Defrost									
Defrost method (EL/GAS)	d01							EL	
Defrost stop temperature	d02					0°C	25°C	6°C	
Interval between defrost starts	d03					OFF	48 hour	8 hour	
Max. defrost duration	d04					0 min	180 min	45 min	
Defrost time delay (after power up)	d05					0 min	60 min	0 min	
Drip-off time	d06					0 min	20 min	0 min	
Fan start delay after defrost	d07					0 min	20 min	1 min	
Fan start temperature	d08					-15°C	0°C	-5°C	
Fan cut-in during defrost (yes/no)	d09							no	
Defrost sensor (yes/no)	d10							yes	
Temperature alarm delay after defrost	d11					0 min	199 min	90 min	
Delay of display view after defrost stop	d12					0 min	15 min	1 min	
Defrost at start-up	d13					no	yes	no	
Fan									
Fan stop on compressor cut-out (yes/no)	F01							no	
Fan stop delay	F02					0 min	30 min	0 min	
Fan stop at open door (yes/no)	F03							yes	
Miscellaneous									
Delay of output signal after start-up	o01					0 s	600 s	5 s	
Digital input signals ⁴⁾ (0 = not used, 1 = door alarm, 2 = defrost, 3 = bus, 4 = Main Switch)	o02							0	
Access code	o05					OFF	100	OFF	
Used sensor type (Pt / PTC)	o06							Pt/PTC	
Real time clock (if fitted)									
Six start times for defrost All can be cut out by setting on OFF	t01- t06					0	23	OFF	
Hour setting	t07					0 hour	23 hour	0 hour	
Minute setting	t08					0 min	59 min	0 min	

Fault code display		Alarm code display		Status code display	
E 1	Fault in controller	A 1	High temperature alarm	S 2	ON-time
E 2	Disconnected room sensor	A 2	Low temperature alarm	S 3	OFF-time
E 3	Short-circuited room sensor	A 4	Door alarm	S 4	Drip-off time
E 4	Disconnected defrost sensor				
E 5	Short-circuited defrost sensor				
E 6	Change battery + Check clock				

- 1) The compressor relay closes when the room temperature exceeds the setting value and differential.
- 2) Alarm is released and sensor failure is indicated, if the room temperature reaches 5°C or more outside the setting range -60° to +50°C.
- 3) After start-up and throughout three days and nights this value is used by the controller. Afterwards the controller is capable by itself to calculate the average value of previous cut-in times.
- 4) Function possibilities with SPST contact, connected to the terminals 3 and 4 are the following:
Door alarm: If SPST is cut out, alarm signalling starts and the fan is stopped, cf. A04 or F03.
Defrost: If SPST is cut in, defrost starts. (However, if d03 is not OFF, defrost will during contact break down start with the programmed time intervals).

Bus: With installed communication card, the position of the SPST contacts will be registered in the BUS system.

Main Switch: Start/stop control

- 5) Factory settings are indicated for standard units. Other code numbers have customized settings.

Factory setting

If you need to return to the factory-set values, it can be done in this way:

- Cut out the supply voltage to the controller
- Keep both buttons depressed at the same time as you reconnect the supply voltage

Ordering

EKC 201, Controllers for panel mounting

Application no.	Code no.							
	Controller + Pt 1000 ohm sensor(s)				Controller + PTC sensor(s)			
	12 V a.c./d.c.		230 V a.c.		12 V a.c. / d.c.		230 V a.c.	
	without alarm relay	with alarm relay	without alarm relay	with alarm relay	without alarm relay	with alarm relay	without alarm relay	with alarm relay
1	084B7025	084B7028	084B7031	084B7032	084B7605	084B7608	084B7611	084B7612
2	084B7026	084B7029			084B7606	084B7609		
3	084B7027	084B7030			084B7607	084B7610		
4	084B7027	084B7030			084B7607	084B7610		

EKC 301, controllers for DIN-rail mounting

Application no.	Code no.			
	Controller + Pt 1000 ohm sensor(s)		Controller + PTC sensor(s)	
	230 V a.c.		230 V a.c.	
	without alarm relay	with alarm relay	without alarm relay	with alarm relay
1	084B7033	084B7036	084B7613	084B7616
2	084B7034	084B7037	084B7614	084B7617
3	084B7035	084B7038	084B7615	084B7618
4	084B7035	084B7038	084B7615	084B7618

Accessories

Plug-in modules

Description	Type	Code no.		
		EKC 201		EKC 301
		12 V	230 V	
Real time clock	EKA 172	084B7070	084B7070	084B7071
Bus communications card FTT *)	EKA 173	084B7125		084B7092
Bus communication card RS 485 *)	EKA 175	084B7126	084B7126	084B7093

*) See installation guide for data communication, RC.8A.C

Transformer, 230/12 V

Code no. 084B7090

Data communication

This page contains a description of a few of the extra functions you obtain, if the controller is extended with data communication.

Example

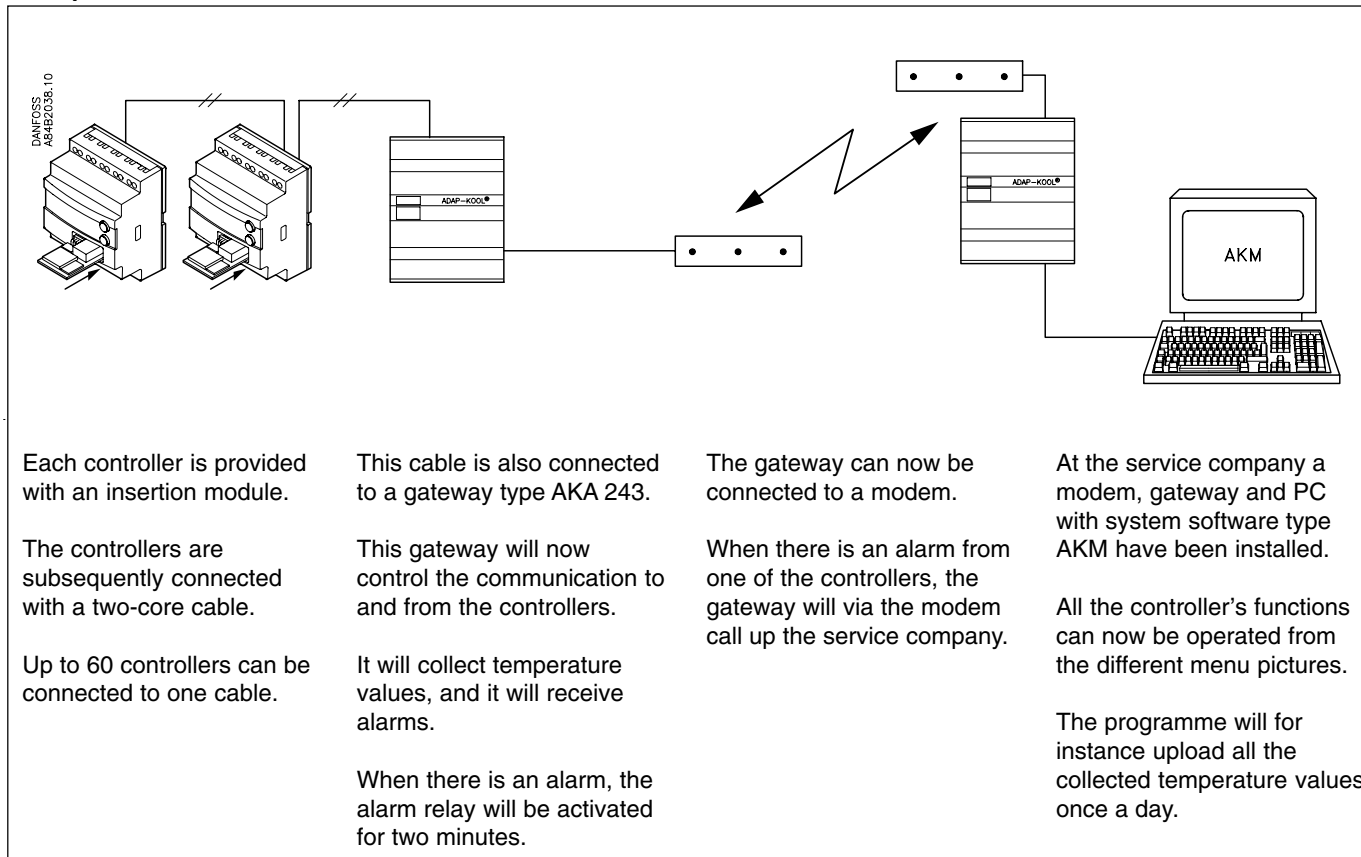

Each controller is provided with an insertion module.

The controllers are subsequently connected with a two-core cable.

Up to 60 controllers can be connected to one cable.

This cable is also connected to a gateway type AKA 243.

This gateway will now control the communication to and from the controllers.

It will collect temperature values, and it will receive alarms.

When there is an alarm, the alarm relay will be activated for two minutes.

The gateway can now be connected to a modem.

When there is an alarm from one of the controllers, the gateway will via the modem call up the service company.

At the service company a modem, gateway and PC with system software type AKM have been installed.

All the controller's functions can now be operated from the different menu pictures.

The programme will for instance upload all the collected temperature values once a day.

Example on menu pictures

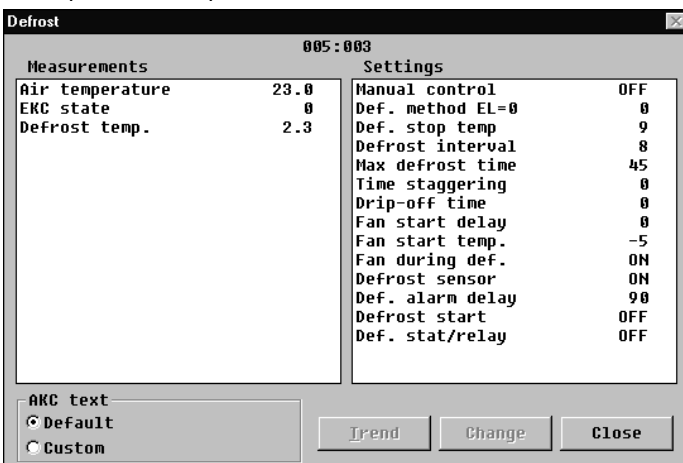

Alarms

If the controller is extended with data communication, it will be possible to define the importance of the transmitted alarms.

The importance is defined with the setting: 1, 2, 3 or 0. When the alarm then arises at some time, it will result in one of the following activities:

1 = Alarm

The alarm message is sent off with alarm status 1. This means that the gateway with address 125 in the system will have its alarm relay output activated for two minutes. Later, when the alarm ceases, the alarm text will be retransmitted, but now with status value 0.

2 = Message

The alarm text is transmitted with status value 2. Later, when the "message" lapses, the alarm text is retransmitted, but now with status value 0.

3 = Alarm

As "1", but the master gateway's relay output is not activated.

0 = Suppressed information

The alarm text is stopped at the controller. It is transmitted nowhere.

- Measurements are shown at one side and settings at the other.
- You will also be able to see the parameter names of the functions on page 4-8.
- With a simple change-over the values can also be shown in a trend diagram.
- If you wish to check earlier temperature measurements, you can see them in the log collection.

List of literature

- | | | |
|---|---------|--|
| Technical brochure | RD.8A.E | Contains the general informations from this manual. |
| Instructions | RI.8A.E | Here you can see how controllers are mounted and programmed. |
| Installation guide for extended operation | RC.8A.C | Here you can see how a data communication connection to ADAP-KOOL® can be established.
Refrigeration controls with EKC LonWorks®. |

Danfoss can accept no responsibility for possible errors in catalogues, brochures and other printed material. Danfoss reserves the right to alter its products without notice. This also applies to products already on order provided that such alternations can be made without subsequential changes being necessary in specifications already agreed.
All trademarks in this material are property of the respective companies. Danfoss and Danfoss logotype are trademarks of Danfoss A/S. All rights reserved.

